

**INDUSTRIAL CRANES**  
NUCLEAR CRANES  
PORT CRANES  
HEAVY-DUTY LIFT TRUCKS  
SERVICE  
MACHINE TOOL SERVICE

**KONECRANES®**  
Lifting Businesses™

**Redefining the standard**  
**CXT® NEO CRANE**



# CXT NEO CRANE

**Agility**



**Power**



# Redefining the standard in general lifting

## Ergonomics

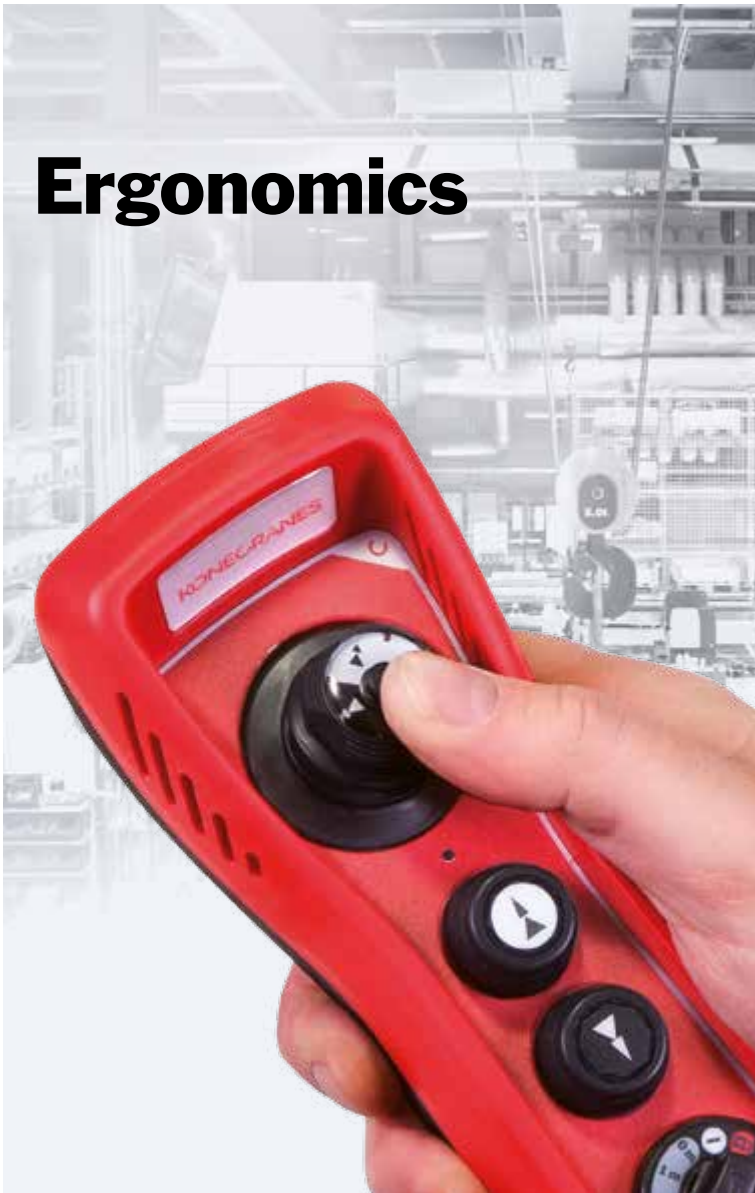

## Preventive maintenance

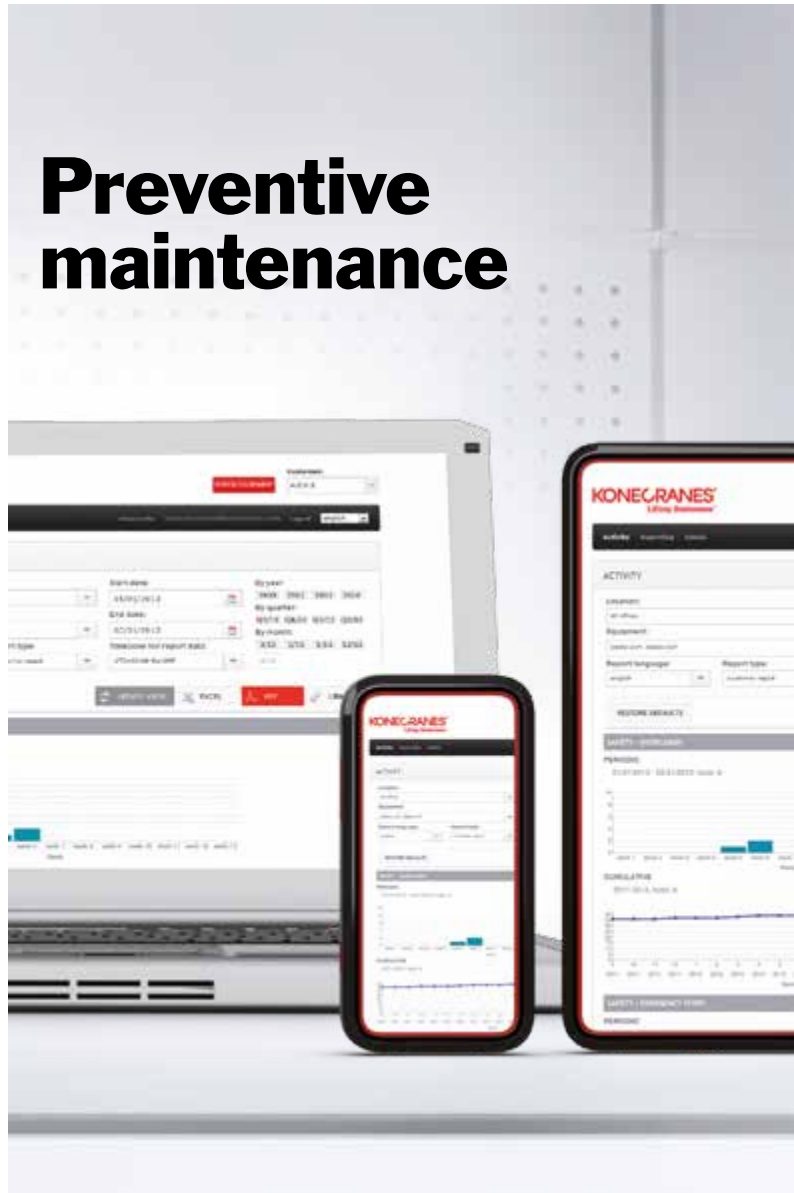

# FREEDOM TO MOVE AND POWER TO LIFT

When it comes to lifting, CXT NEO crane is a powerful machine – but also an agile one. Its ergonomic design and new MiniJoystick radio enable faster operations. Inverter hoisting provides power and accuracy with load positioning, and the TRUCONNECT® Remote Service package seals the deal. That's what we mean by redefining the standard in general lifting.

## OPTIMIZED MAINTENANCE ACTIVITIES

based on usage data  
with TRUCONNECT  
Remote Monitoring.

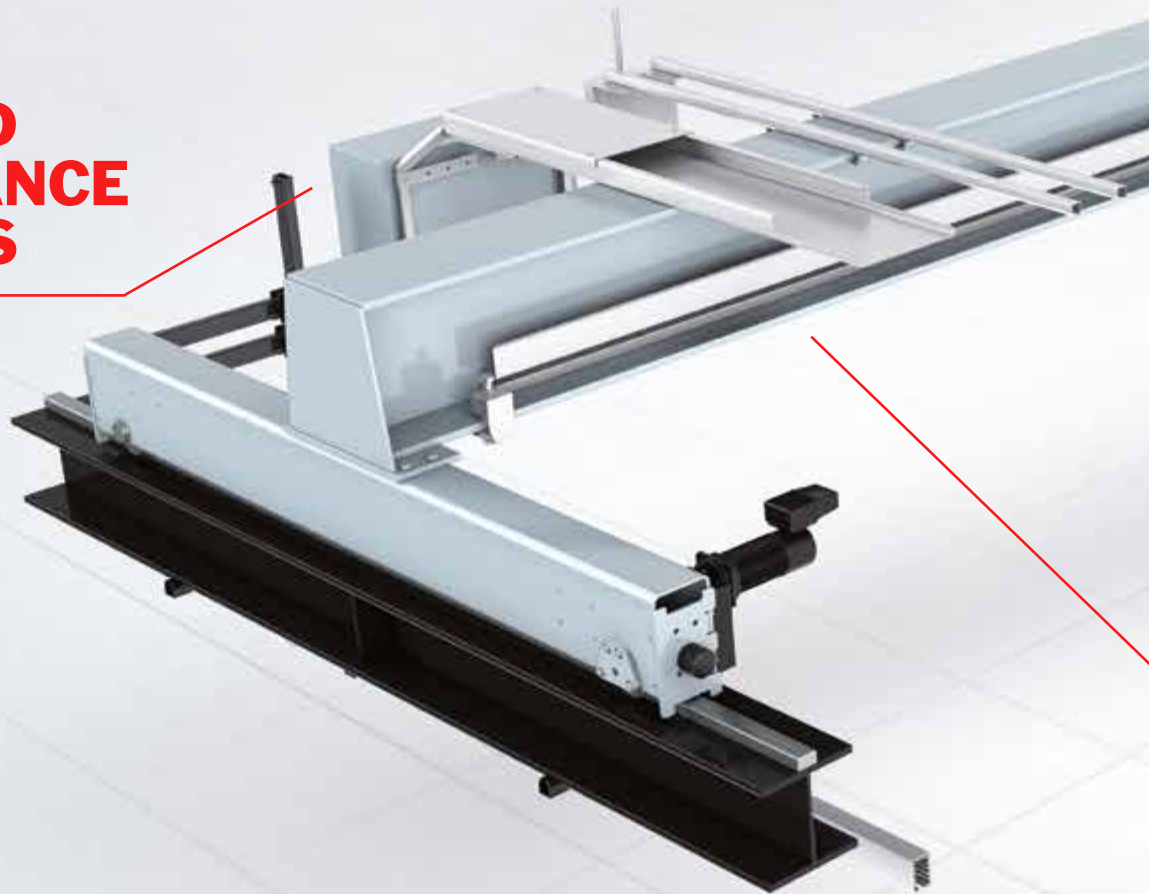





UP TO 12.5 TONS

of lifting capacity and up to 25 tons with two similar hoists.

IMPROVED SAFETY

with energy chain, which protects the power and control cables from mechanical wear and reduces the risk of external damage.

INCREASED ACCURACY IN LOAD CONTROL

thanks to stepless hoisting speed.

LONGER LIFECYCLE

thanks to inverter hoisting that reduces mechanical stress on structures.



# HIDDEN POWER

**Energy chain gives CXT NEO crane its sleek and modern look and, more importantly, improves the safety of the crane's working environment.**

Energy chain is an easy way to feed the primary power and control cables along the crane bridge. It holds all the cables from the main electrical cubicle to the hoist in a composite chain.

The composite chain moves along a channel that is attached to the main girder of the crane. There are no visible electrical cables hanging from the crane.

Energy chain increases the working space under the crane, protects the power and control cables from mechanical wear and reduces the risk of external damage.

## ENERGY CHAIN BENEFITS

- Improved safety in the working environment
- Increased working space
- Reduced cable wear and risk of external damage
- A modern look to your crane

# Agility

**ENERGY CHAIN'S** simplified design eliminates the need for additional parts associated with common festoon systems.



## SINGLE- AND DOUBLE-GIRDER CRANES WITH ENERGY CHAIN



Energy chain protects the power and control cables from mechanical wear.



## NEO PACKS MORE PUNCH

**Behind CXT NEO crane's power is the energy-efficient inverter hoisting technology that provides accuracy with load positioning and controlled slow-speed operation.**

Inverter hoisting enables stepless hoisting speeds. It allows very slow speeds, which are important in moments of load lift-off and lowering. It also enables faster lifting by as much as 50%.

With inverter hoisting, an empty load hook can be driven at speeds of up to 50% faster compared to a loaded hook, allowing the operator to choose the most efficient way to operate the hoist.

Inverter hoisting makes soft start-ups possible and reduces the stress affecting the crane and the structures. It means a longer lifetime for your crane and lower life cycle costs.

### INVERTER HOISTING BENEFITS

- Up to 50% faster lifting
- Better accuracy with load positioning
- Controlled slow-speed operation
- Longer lifetime and lower life cycle costs





# Power

**INVERTER HOISTING (ASR)** technology enables faster load cycles, stepless speed control and precise load positioning.

## INVERTER HOISTING (ASR) TECHNOLOGY LOAD SPECTRUM & SPEEDS

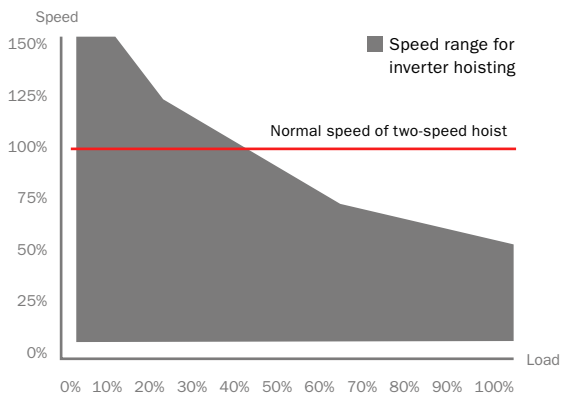

**ASR=Adaptive Speed Range**

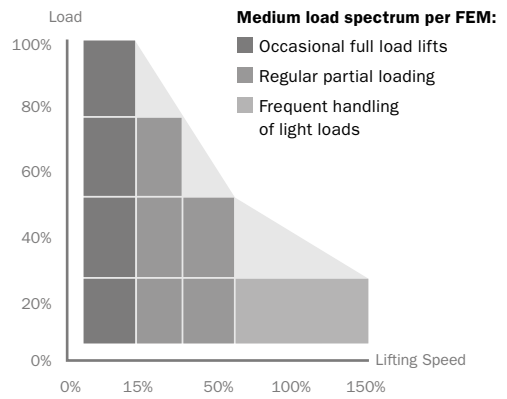

**Inverter hoisting (ASR) motor characteristics:**

- Fast speed for light loads
- Medium speed for partial loading
- Safety speed for heavy loads



# TAKING ERGONOMICS TO THE NEXT LEVEL

**All of the lifting power in CXT NEO crane is easy to control with the ergonomic Konecranes MiniJoystick radio.**

The MiniJoystick radio takes the ergonomics of controlling cranes to the next level. It is lightweight and easy to use.

The joystick is for controlling the traveling movement of the crane and hoist, whereas the buttons are for lifting and lowering. The joystick allows the operator to control the load with just a single grip and enables the operator to concentrate fully on the load.

## MINIJOYSTICK BENEFITS

- **Ease of use makes operations faster**
- **Single-grip control enables full concentration on the load**
- **Light weight and ergonomic controls reduce operator fatigue**



# Ergonomics

**MINIJOYSTICK RADIO** provides freedom to move and makes speed adjustments easy.

## MINIJOYSTICK RADIO

**BRIDGE AND TROLLEY MOVEMENTS**  
The joystick is for controlling the traveling movement of the crane and hoist.

**MULTIFUNCTION KEY**  
The rotatable function key makes it possible to have multiple functions for just one control element.

**LIFTING AND LOWERING MOVEMENTS**  
Push-buttons are for controlling stepless hoisting movements.

**EMERGENCY STOP**







# NEO HELPS YOU MAKE INTELLIGENT MAINTENANCE DECISIONS

**A quality crane, properly used and well maintained, should provide years of trouble-free lifting. If you start with a great crane and then work with us to care for it professionally, predictability can improve, helping you make decisions about maintenance and productivity.**

## **SERVICE PROGRAMS THAT FIT YOUR NEEDS**

An active preventive maintenance program is recommended for your CXT NEO. We can create a maintenance plan based on your equipment, application and duty cycle.

**The CARE Preventive Maintenance Program** is our most popular service offering and includes preventive maintenance inspections and routine maintenance. If you need less, **the CONDITION Inspection Program** will help you comply with local statutory requirements and support your in-house maintenance.

## **BACKED BY A SOLID WARRANTY**

**Combining preventive maintenance with TRUCONNECT Remote Monitoring gives you an optimal safety and production environment. And when you have a Konecranes Service program and Remote Monitoring in place, you can extend the CXT standard warranty – which includes replacement or repair of faulty parts and components during regular hours – up to 10 years.**



# Get insights into your crane usage

**TRUCONNECT REMOTE MONITORING** uses sensors to collect data, such as running time, motor starts, work cycles and emergency stops, providing visibility to crane usage. The data is accessible on demand in the yourKONECRANES.com customer web portal where aggregated data can be viewed, analyzed and shared quickly, for a single asset or an entire fleet.



## TRUCONNECT REMOTE MONITORING



Sensors gather usage data—running time, motor starts, work cycles and brake condition.



Data is transmitted to the Konecranes Remote Data Center.

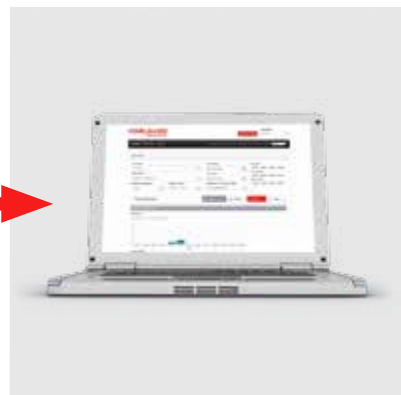

Usage and maintenance data can be viewed on yourKONECRANES.com.

# CXT NEO CRANE FACTS AT A GLANCE

	SINGLE-GIRDER		UNDER-RUNNING		DOUBLE-GIRDER
HEADROOM	Low	Normal	Low	Normal	
<b>FEATURES</b>					
ASR inverter hoisting	STANDARD	STANDARD	STANDARD	STANDARD	STANDARD
MiniJoystick radio	STANDARD	STANDARD	STANDARD	STANDARD	STANDARD
Energy chain power feeding for trolley	STANDARD	STANDARD	STANDARD	STANDARD	STANDARD
TRUCONNECT Remote Monitoring	STANDARD	STANDARD	STANDARD	STANDARD	STANDARD
Extended warranty	OPTIONAL	OPTIONAL	OPTIONAL	OPTIONAL	OPTIONAL
RAL7035 grey color	STANDARD	STANDARD	STANDARD	STANDARD	STANDARD
RAL1028 yellow color	OPTIONAL	OPTIONAL	OPTIONAL	OPTIONAL	OPTIONAL

## STANDARD AND OPTIONAL COLORING



STANDARD RAL7035 grey color

OPTIONAL RAL1028 yellow color

## LOAD RANGE AND DUTY CLASS

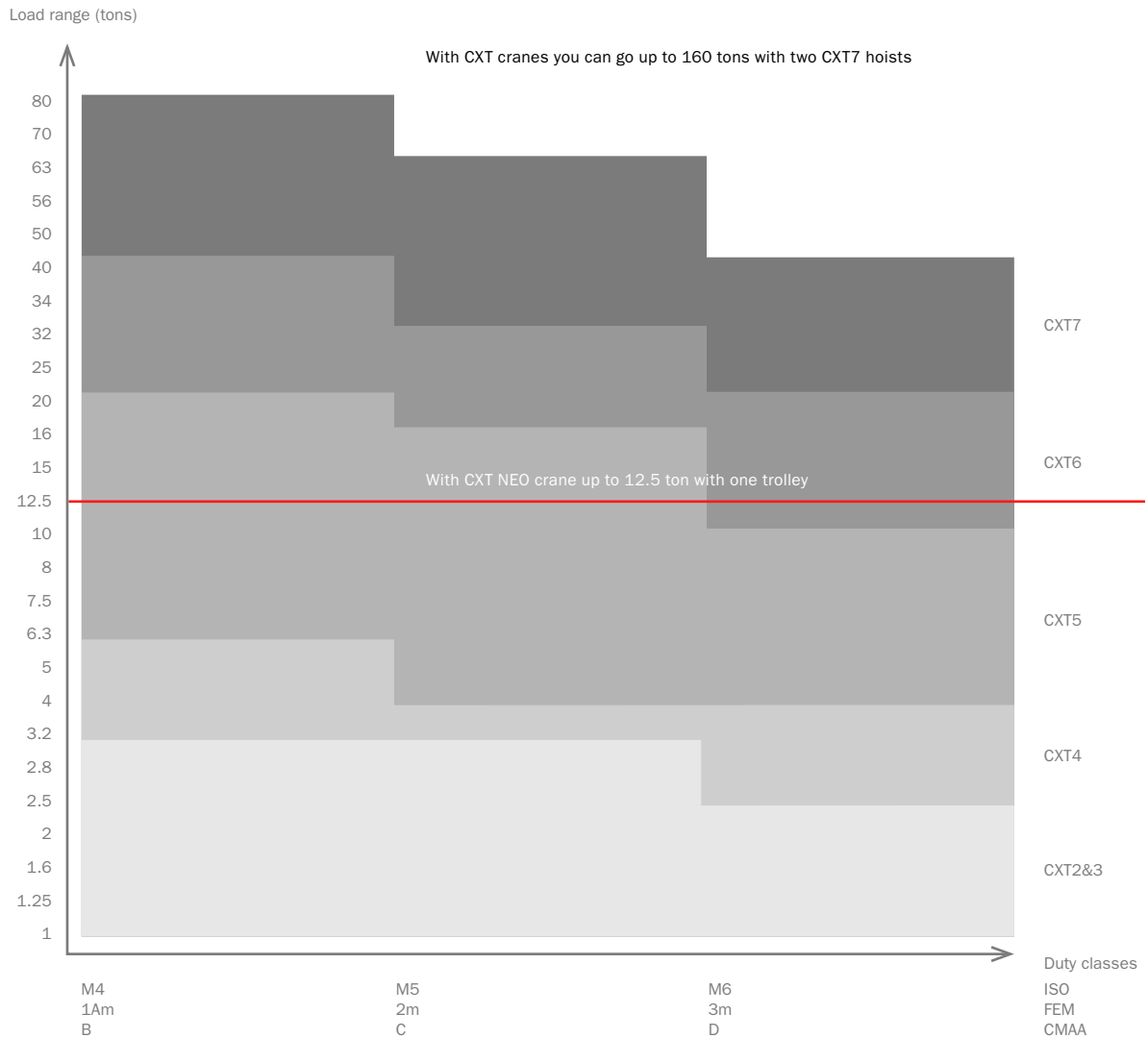

### WHEN YOU NEED MORE LIFTING CAPACITY, GET TO KNOW OUR CXT WIRE ROPE HOIST CRANES RANGE

CXT cranes can be implemented with a single-girder or double-girder construction, a fixed single-girder system (monorail) or with an under-running construction.

With different trolley configurations, CXT wire rope hoist cranes maximize the lifting height and easily fit into different kinds of buildings:

- Low headroom trolleys up to 12.5 t
- Normal headroom trolleys up to 40 t
- Double-girder trolleys up to 80 t
- Five frame sizes up to 80 t
- Fixed hoists up to 80 t



INDUSTRIAL  
CRANES



NUCLEAR  
CRANES



PORT  
CRANES



HEAVY-DUTY  
LIFT TRUCKS



SERVICE  
LIFT TRUCKS



MACHINE  
TOOL  
SERVICE



Konecranes is a world-leading group of Lifting Businesses™ offering lifting equipment and services that improve productivity in a wide variety of industries. The company is listed on Nasdaq Helsinki Ltd (symbol: KCR1V). With almost 12,000 employees at 600 locations in nearly 50 countries we have the resources, technology and determination to deliver on the promise of Lifting Businesses™.

© 2016 Konecranes Plc. All rights reserved. 'Konecranes', 'Lifting Businesses', 'CXT', 'TRUCONNECT', and  are either registered trademarks or trademarks of Konecranes Plc.

