

Redefining the standard
CXT[®] NEO CRANE

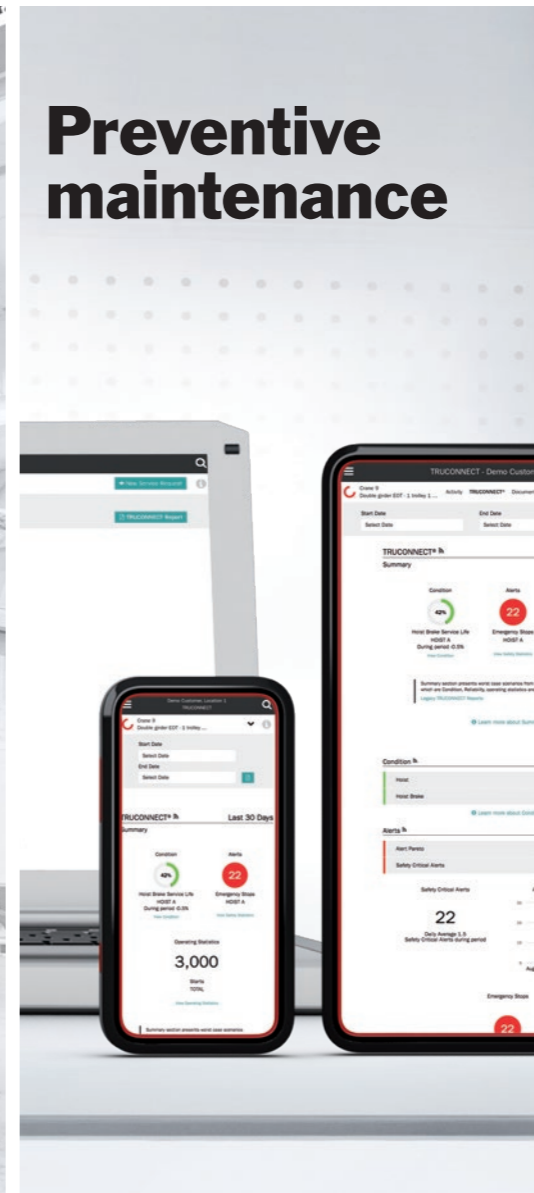

CXT NEO CRANE

Redefining the standard in general lifting



FREEDOM TO MOVE AND POWER TO LIFT

When it comes to lifting, the CXT NEO is both powerful and agile. Its ergonomic design and intuitive radio control streamline operations. Inverter hoisting provides strength and accuracy with load positioning, and the TRUCONNECT® Remote Service package helps keep it running smoothly. That's what we mean by "redefining the standard" in general lifting.

OPTIMIZED MAINTENANCE ACTIVITIES

using insights drawn from TRUCONNECT Remote Monitoring data.

UP TO 80 TONS

of lifting capacity and up to 160 tons with two similar hoists.

IMPROVED SAFETY

with energy chain, which protects power and control cables from mechanical wear and reduces the risk of external damage.

INCREASED ACCURACY IN LOAD CONTROL

thanks to stepless ASR hoisting speeds and the Rope Angle Features Module.

LONGER LIFECYCLE

thanks to inverter hoisting that reduces mechanical stress on structures and improves hoisting brake lifetime.





Agility

Simplified **ENERGY CHAIN'S** design eliminates the need for additional parts commonly used in festoon systems.

HIDDEN POWER

The energy chain gives the CXT NEO crane its sleek and modern look, and more importantly, improves the safety of the crane's working environment.

It's an easy way to feed the primary power and control cables along the crane bridge. The energy chain holds all the cables from the main electrical cubicle to the hoist in a composite chain.

The composite chain moves along a channel attached to the main girder. There are no visible electrical cables hanging from the structure.

The energy chain increases the working space under the crane, protects the power and control cables from mechanical wear and reduces the risk of external damage.

ENERGY CHAIN BENEFITS

- Improved safety around the crane
- More working space
- Less cable wear and risk of external damage
- Modern look

SINGLE- AND DOUBLE-GIRDER CRANES WITH AN ENERGY CHAIN



The energy chain protects power and control cables from mechanical wear.

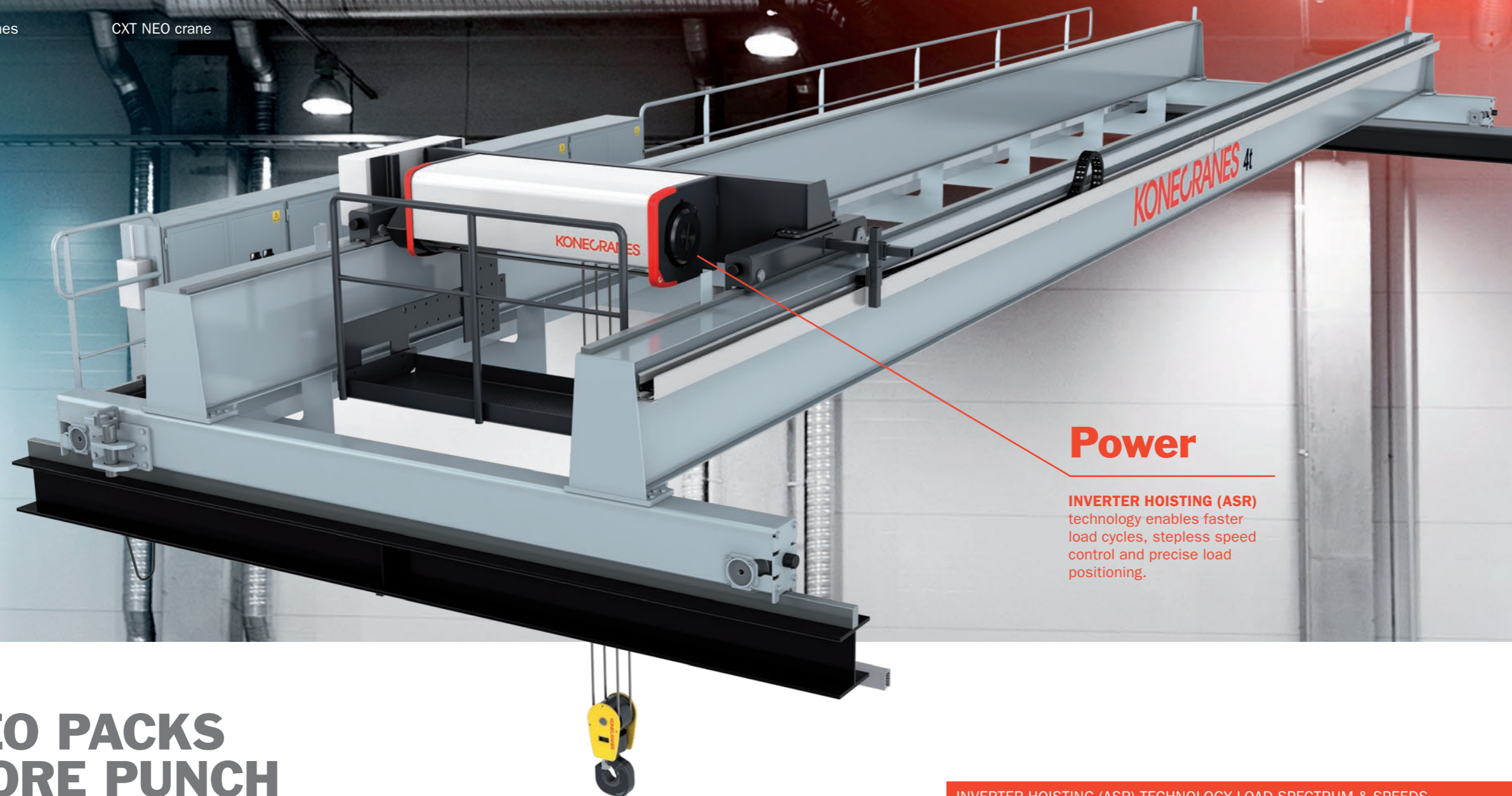

Power

INVERTER HOISTING (ASR) technology enables faster load cycles, stepless speed control and precise load positioning.

NEO PACKS MORE PUNCH

Behind CXT NEO crane's power is the energy-efficient inverter hoisting technology that provides accuracy with load positioning and controlled slow-speed operation.

Inverter hoisting enables stepless hoisting speeds. It allows very slow speeds, which are crucial when picking up and lowering loads. It also enables faster lifting by as much as 50%.

The operator can also lift loads and drive an empty hook up to 50% faster. This means more efficient hoist movement.

Inverter hoisting makes soft start-ups possible and reduces the stress affecting the crane and its structure. This means a longer lifetime for your crane and lower lifecycle costs.

INVERTER HOISTING BENEFITS

- Up to 50% faster lifting
- Better accuracy with load positioning
- Controlled slow-speed operation
- Lower lifecycle costs

INVERTER HOISTING (ASR) TECHNOLOGY LOAD SPECTRUM & SPEEDS

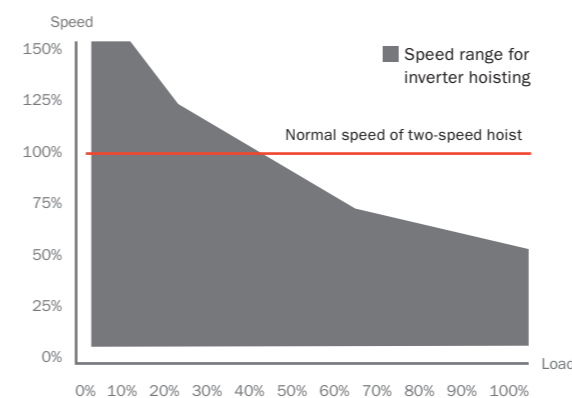

ASR=Adaptive Speed Range

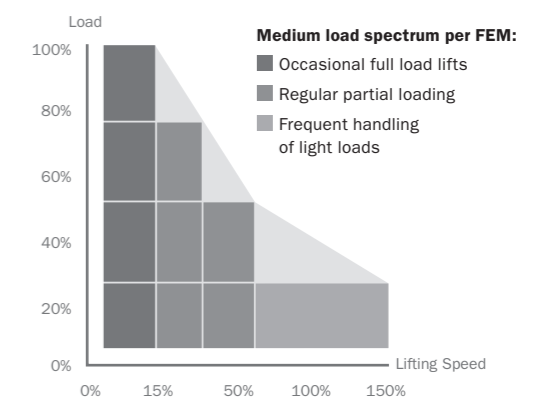

Inverter hoisting (ASR) motor characteristics:

Fast speed for light loads
Medium speed for partial loading
Safety speed for heavy loads



TAKING ERGONOMICS TO THE NEXT LEVEL

All of the lifting power in CXT NEO crane is easy to control with ergonomic radios.

Lightweight and easy-to-use radio control takes the ergonomics of controlling cranes beyond expectations.

Radio control allows the operator to control the load with a single grip, so their concentration is more fully on the load.

Radio benefits

- Ease of use makes operations faster
- Single-grip control improves concentration on the load
- Lightweight and ergonomic controls reduce operator fatigue

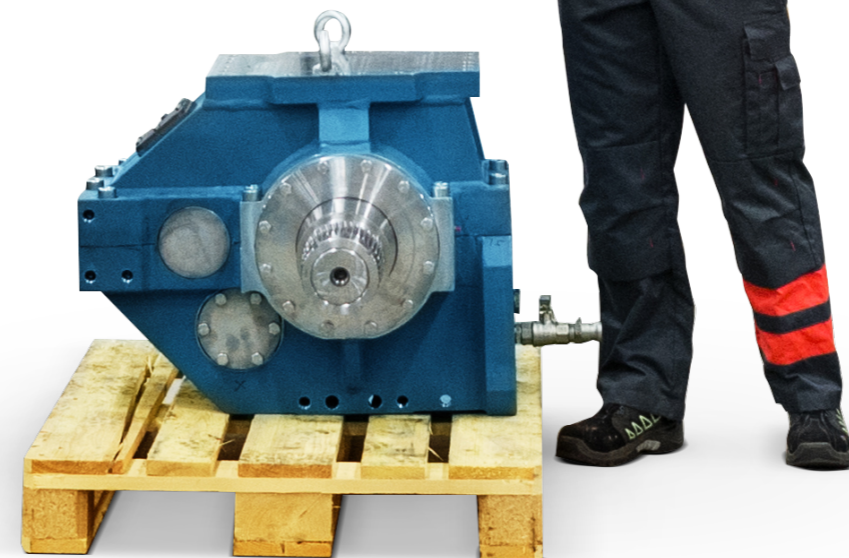



Get insights into your crane usage

TRUCONNECT REMOTE MONITORING uses sensors to collect data – such as running time, motor starts, work cycles and emergency stops. Brake and inverter monitoring is also available.

TRUCONNECT data is viewable on our cloud-based customer portal – yourKONECRANES.com. If you have a maintenance agreement with us, your maintenance data and asset details are also available on the portal, giving you a transparent view of events and activities over any selected time interval.

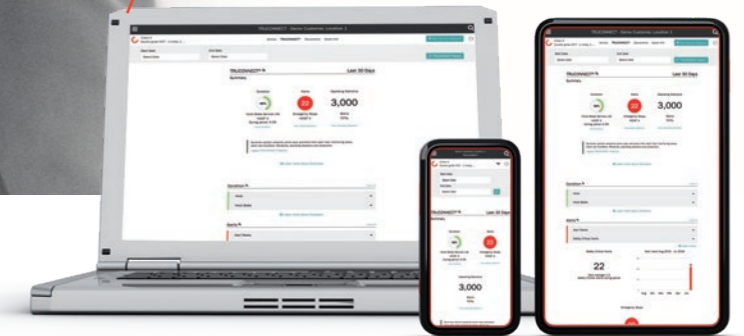

NEO HELPS YOU MAKE INTELLIGENT MAINTENANCE DECISIONS

A quality crane, properly used and well maintained, should provide years of trouble-free lifting. If you start with a great crane and then work with us to care for it professionally, predictability can improve, helping you make decisions about maintenance and productivity.

SERVICE PROGRAMS THAT FIT YOUR NEEDS

An active preventive maintenance program is recommended for your CXT NEO. We can create a maintenance plan based on your equipment, application and duty cycle.

The **CARE Preventive Maintenance Program** is our most popular service offering and includes preventive maintenance inspections and routine maintenance. If you need less, the **CONDITION Inspection Program** will help you comply with local statutory requirements and support your in-house maintenance.

BACKED BY A SOLID WARRANTY

Combining preventive maintenance with TRUCONNECT Remote Monitoring gives you an optimal safety and production environment. And when you have a Konecranes Service program and Remote Monitoring in place, you can extend the CXT standard warranty – which includes replacement or repair of faulty parts and components during regular hours – for up to 10 years.

TRUCONNECT REMOTE MONITORING



Sensors gather usage data - running time, motor starts, work cycles and brake condition.

Data is transmitted to the Konecranes Remote Data Center.

Usage and maintenance data can be viewed on yourKONECRANES.com.



SAFER LOAD HANDLING

The Rope Angle Features Module provides crane operators with handy solutions for everyday lifting challenges. Features are based on the rope angle measurement.

The main target is to prevent any side pull or load swing when the load is lifted and moved. With additional software and a measurement device (inclinometer) mounted to the hoist, it's possible to know the rope angle and allow the crane control system to make corrective actions based on rope angle measurement data.



FOLLOW ME[®] makes lifting operations much faster because the crane can be moved above the load by simply guiding the hook by hand. This feature reduces load cycle times by making it much easier and faster to load and unload the crane.

(* Follow Me is recommended for up to 10t cranes)



HOOK CENTERING is designed to eliminate side pull during lifting by positioning the bridge and trolley automatically directly over the load. This feature means less wear and tear on your crane's components, faster load cycle times and ease of operation.



SNAG PREVENTION is designed to stop all crane movement if the hook, sling or load accidentally gets caught on something. This safety function reduces the risk of hazardous situations while moving loads and helps to prevent damage to the load, crane and surrounding area.

CXT NEO CRANE FACTS AT A GLANCE

	SINGLE-GIRDER		UNDER-RUNNING		DOUBLE-GIRDER
HEADROOM	Low	Normal	Low	Normal	
FEATURES					
ASR inverter hoisting	STANDARD	STANDARD	STANDARD	STANDARD	STANDARD
Radio	STANDARD	STANDARD	STANDARD	STANDARD	STANDARD
Energy chain power feeding for trolley	STANDARD	STANDARD	STANDARD	STANDARD	STANDARD
TRUCONNECT Remote Monitoring	STANDARD	STANDARD	STANDARD	STANDARD	STANDARD
Extended warranty	OPTIONAL	OPTIONAL	OPTIONAL	OPTIONAL	OPTIONAL
Rope Angle Features Module	OPTIONAL	OPTIONAL	OPTIONAL	OPTIONAL	OPTIONAL
RAL7035 grey color	STANDARD	STANDARD	STANDARD	STANDARD	STANDARD
RAL1028 yellow color	OPTIONAL	OPTIONAL	OPTIONAL	OPTIONAL	OPTIONAL

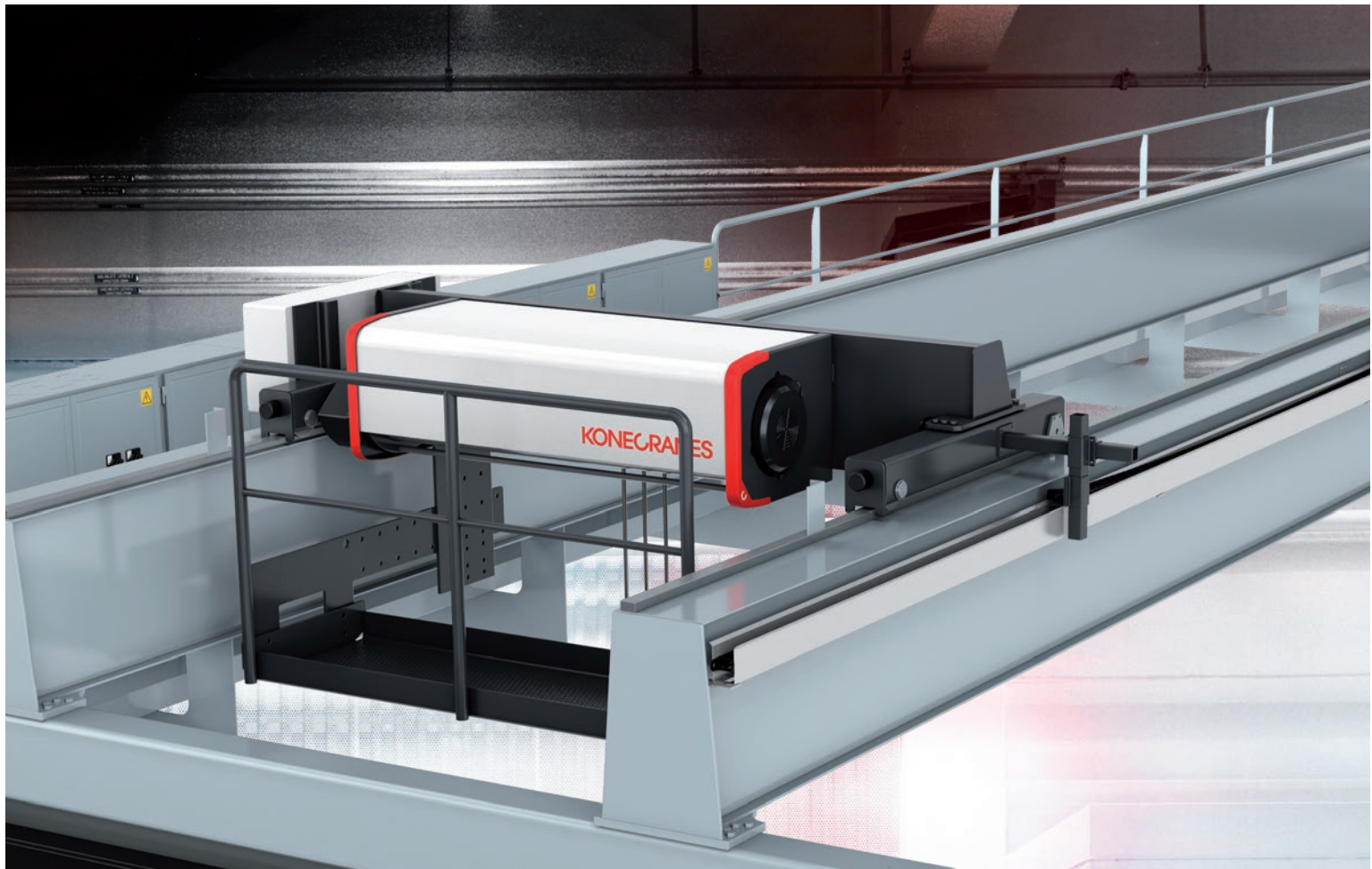

Konecranes is a world-leading group of Lifting Businesses™, serving a broad range of customers, including manufacturing and process industries, shipyards, ports and terminals. Konecranes provides productivity enhancing lifting solutions as well as services for lifting equipment of all makes. In 2017, Group sales totaled EUR 3,136 million. The Group has 16,400 employees at 600 locations in 50 countries. Konecranes shares are listed on the Nasdaq Helsinki (symbol: KCR).

© 2018 Konecranes. All rights reserved. 'Konecranes', 'Lifting Businesses' and , 'CXT', 'SMARTON' and 'TRUCONNECT' are either registered trademarks or trademarks of Konecranes Global Corporation.